

# The Challenge of connecting bamboo

Author: Munir Vahanvati

Institution: Director, Giant Grass and Vice president, Bamboo Society of Australia

Email: [munir@giantgrassdesign.com](mailto:munir@giantgrassdesign.com)

## Abstract:

Building with bamboo is becoming very popular throughout the world with many prominent architects now using bamboo as a construction material. Bamboo architecture has taken a big leap in developing countries in recent years and has become a symbol of eco-friendly design and sustainability. Despite its increasing popularity it is still the domain of a few experienced builders who know how to build with bamboo.

At Giant Grass our focus is on the utilisation of bamboo, especially as a building material. Over the past 10 years we have built various structures, conducted hands-on construction workshops and explored different connection details with bamboo. One of the key challenges with bamboo is how to connect different poles in order to create a strong structure. The hollow cylindrical form along with varying thickness means the most common timber construction details like nails and screws are not suitable. In traditional cultures lashing and pinning was the most common form of connection. In the 20<sup>th</sup> century Simon Velez pioneered the use of steel bolts and cement, which changed how bamboo structures were built. Designers and engineers have used various other connection details like clamps, plates, hubs, etc. to create bamboo structures but there are no standard connections available in the market.

This paper outlines various bamboo connection techniques that Giant Grass has explored over the past 10 years. Further the paper discusses a new system of connecting bamboo that would make it easier for people to build with bamboo and increase utilization of bamboo both in developing and developed countries. The paper outlines the possibilities of the system and how it would further promote the use of bamboo.

## Introduction

Building with bamboo is becoming very popular throughout the world with many prominent architects now using bamboo as a construction material. This is evident from design blogs and websites, which showcase increasing number of bamboo buildings. Bamboo architecture has taken a big leap in developing countries in recent years and has become a symbol of eco-friendly design and sustainability led by buildings like the Green School in Bali (Figure 1).



Figure 1

In western countries such as Australia use of bamboo is gaining popularity with greater number of household goods now made out of bamboo. Bamboo floorboards are also very popular as a sustainable alternative and are used extensively in renovations and new construction. People are getting more aware of the potential of bamboo as a sustainable material and are interested in learning and doing more with bamboo. Lack of building regulations for bamboo makes it difficult to build large buildings out of bamboo in Australia but there are plenty of opportunities to build smaller structures. Majority of the people who are interested in building with bamboo find it challenging as there are no specific joineries and systems to use and treated bamboo poles are expensive and limited in supply.

## Challenges of building with bamboo in Australia

At Giant Grass our focus is on promoting the use and value addition of bamboo in construction industry. To achieve this we have used hands-on construction workshop as a model of teaching people how to build with bamboo whilst exploring new designs and connections. Over the past 10 years we have conducted various bamboo workshops with university students, tribal people, kids and community members in general. During these workshops we have used the process of experiential

**Theme: Architecture, Engineering and Social Housing**

learning where we have tested our design, built various structures, tested connection details and used our learning for future designs (Figure 2).

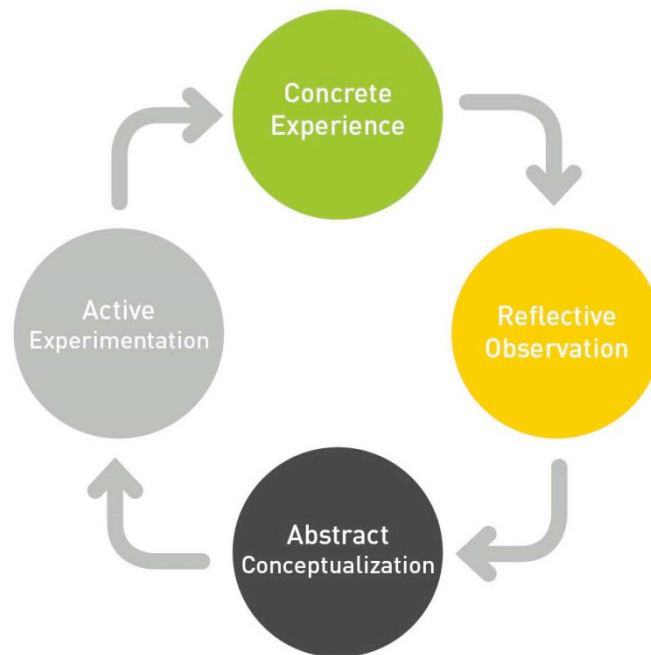

Figure 2

Building with bamboo is gaining popularity in Australia but there are quite a few challenges including supply and cost of raw material, lack of building regulation, lack of knowledge and skill in working with bamboo. The workshops have provided us great insight into some of the challenges in working with bamboo in Australia.

One of key challenges that inhibit the use of bamboo is connecting bamboo poles. Bamboo has a hollow cylindrical form with varying wall thickness and taper. The fiber in bamboo runs along the length with only the nodes providing lateral strength making it susceptible to cracking under stress. The most common timber construction system details such as nails or screws increase the chance of cracking with a risk of them becoming loose. This makes such connections unsuitable for use with bamboo.

## Types of bamboo connections

There are various ways of connecting bamboo. Traditionally tying with natural fiber and using bamboo pins was the most common approach. In the 20<sup>th</sup> century Simon Velez along with Marcelo Villegas pioneered the use of steel bolts and concrete, which changed how bamboo structures are built. As part of the workshops we have tried various connection details, which are discussed below.

### Lashing and pinning

Traditionally lashing was the prominent form of bamboo connection. Generally natural fiber rope like sisal or palm is used for lashing but it is also possible to use polypropylene ropes (Figure 3). There are various types of lashing knots but the most common one include square lashing, diagonal lashing and shear lashing (Figure 4). Although it is possible to use lashing on its own many times it is used in combination with bamboo pins making the joints stronger.



Figure 3



Figure 4

Lashing provides great flexibility in connecting bamboo but it is very time consuming and requires highly developed skill, otherwise the rope tends to get loose over a period of time. Natural fiber ropes need to be replaced every few years if they are exposed to the elements.

### Steel bolt

The bamboo poles are connected using threaded rod with nuts and washers at both ends. Use of steel bolts allows creating complex connections, which are not possible with lashing. Concrete is poured inside the bamboo internode for the joints that have high shear stress (Figure 5)



Figure 5

Steel bolts make building a bamboo structure much quicker than lashing. Use of bolts requires a good understanding of structural design principles and the principle of triangulation, as each joint is a pin joint. Once the structure is built it is difficult to remove and replace poles.

### Clamps

Many people have used clamps to connect bamboo and create structures. As the name suggested the connectors are in the form of a clamp that hold to the external of the bamboo poles. Majority of the

**Theme: Architecture, Engineering and Social Housing**

time these clamps are custom fabricated for a particular project. We used standard fencing clamps for building a Bamboo Greenhouse as an experiment to check how difficult it would be to build with standard connector (Figure 6).



Figure 6

Though clamps provide great flexibility and ease of construction, there are no clamping connectors readily available for bamboo. Standard clamping connectors for steel construction are not suitable for bamboo as it has varying diameter and taper.

## Hubs

Hub connector generally consists of a central ring connector, which is connected to bamboo using a steel plate or rod. Polypipe can be used with bamboo to create a hub connector, which is bolted in the middle (Figure 7). Hub connectors can also be combined with clamps as we did in the Bamboo Greenhouse (Figure 8).



Figure 7



Figure 8

Hub connectors are generally used to join many pieces of bamboo in the middle. These type of connectors are useful to create geodesic dome or other geometric forms. These connectors are generally custom fabricated for specific projects and are not readily available.

**Theme: Architecture, Engineering and Social Housing**

## Brackets and plates

Brackets or plates are used to connect the bamboo in the same plane and useful to build trusses or other similar structural elements. Brackets are generally L-shaped pieces made out of steel and bolted to bamboo to create 90° connections (Figure 9). Plates can be made from steel or plywood and are used to connect various bamboo poles using bolts (Figure 10)



Figure 9



Figure 10

It is difficult to find steel brackets or plates for use with bamboo; generally they need to be custom fabricated. They are generally useful for some structural components but mainly in 2 dimensional planes.

## The Bamboo Clamp Connector

The Bamboo Clamp Connector is designed to make building with bamboo easier and faster. It uses the best aspects from various types of connections discussed above. The connector is designed for small to medium sized structures and mainly for Do It Yourself (DIY) use.

The connector uses a clamp effect to connect bamboo. The clamp is made of four prongs making it suitable to be used with different sized bamboo and overcome the issue of non-standard diameter and taper.

The design has been developed after extensive prototyping of various options. The final design is a balance of functionality and weight creating a joint that is flexible and suitable for most options (Figure 11).



Figure 11

## Components

The connector includes various components that make it modular and flexible. All these components combine to create various design opportunities that are illustrated in the next section.

### Clamp

Clamp is the main component that is fixed at the ends of the bamboo pole. The clamp includes four prongs that attach to the bamboo pole and are tightened by cone shaped cup. These clamps are then connected to a central ring (Figure 12).

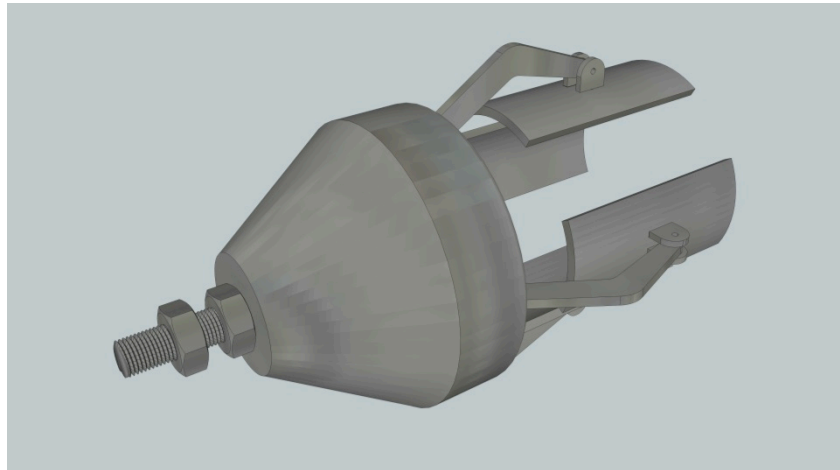

Figure 12

### Ring

The ring is a curved edge and has vertical slots to connect the clamps. The curved surface provides maximum flexibility so that bamboo poles can be connected at different angles. The ring comes with various options including 5, 6 and 8 slots (Figure 13).

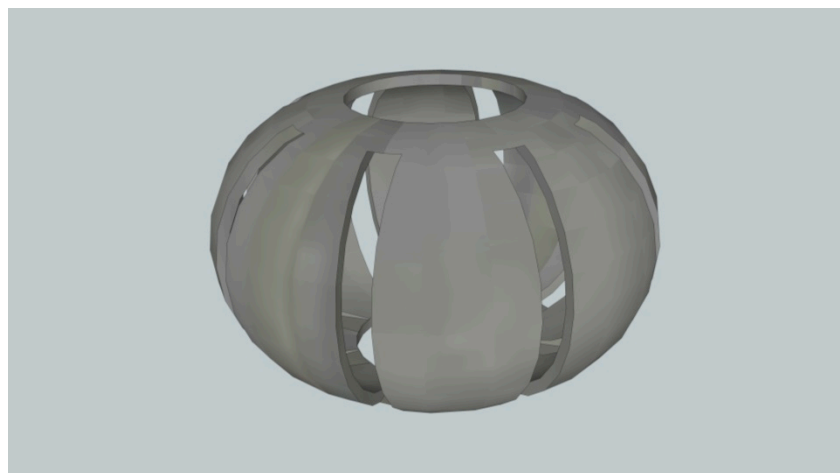

Figure 13

### Circular disk

The circular disk attaches to the ring allowing bamboo poles to be connected perpendicular to the ring. This increases the possibility of the type of structures that can be built with the connection and allows for the construction of standard post beam type of structures (Figure 14).

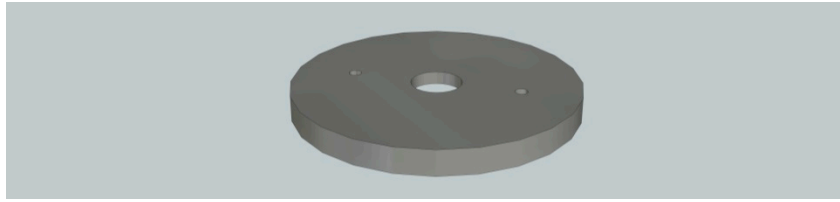

Figure 14

### Footing plate

A variation of the central ring the footing plate allows for the structure to be fixed to the ground temporarily or permanently using pegs or bolts (Figure 15).

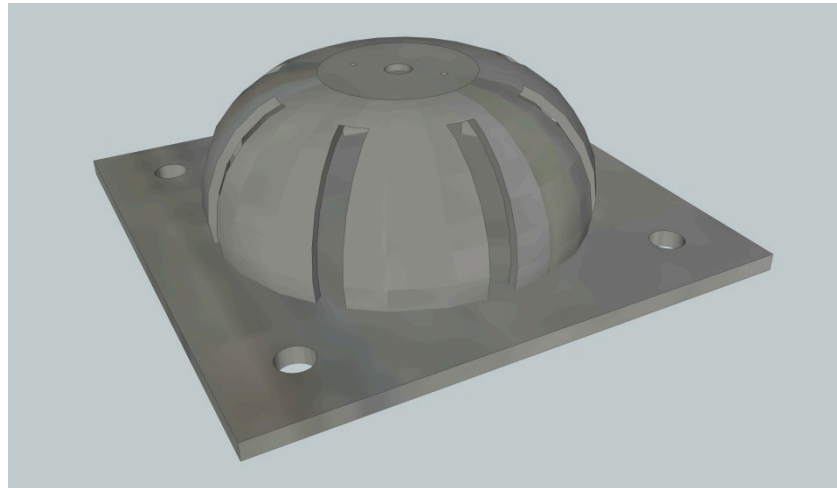

Figure 15

### Design opportunities

The modular and flexible nature of the Bamboo Clamp Connector provides various design opportunities. The components can be connected in different combinations to create a variety of joints (Figure 16).

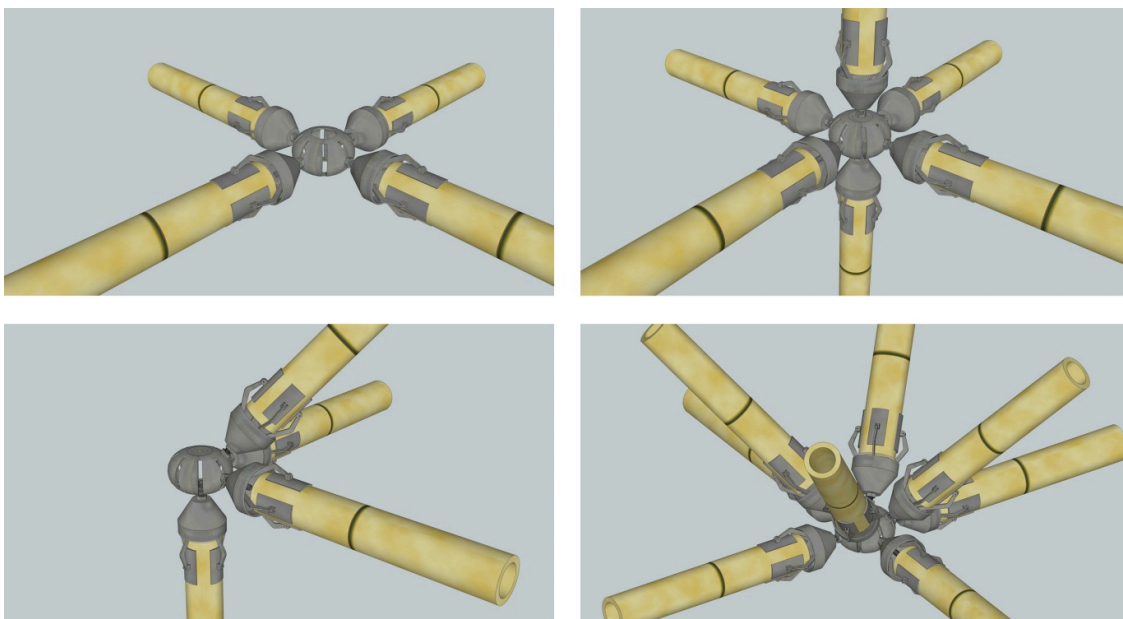

Figure 16



The connection system makes it very easy to build simple geometric structures like a square gazebo (Figure 17). The framing can then be covered with different roofing materials of temporary or permanent nature.



The range of connections opens up possibilities to design and build various geometric structures like geodesic domes, vaults, space frames, gazebos, etc. (Figure 18).

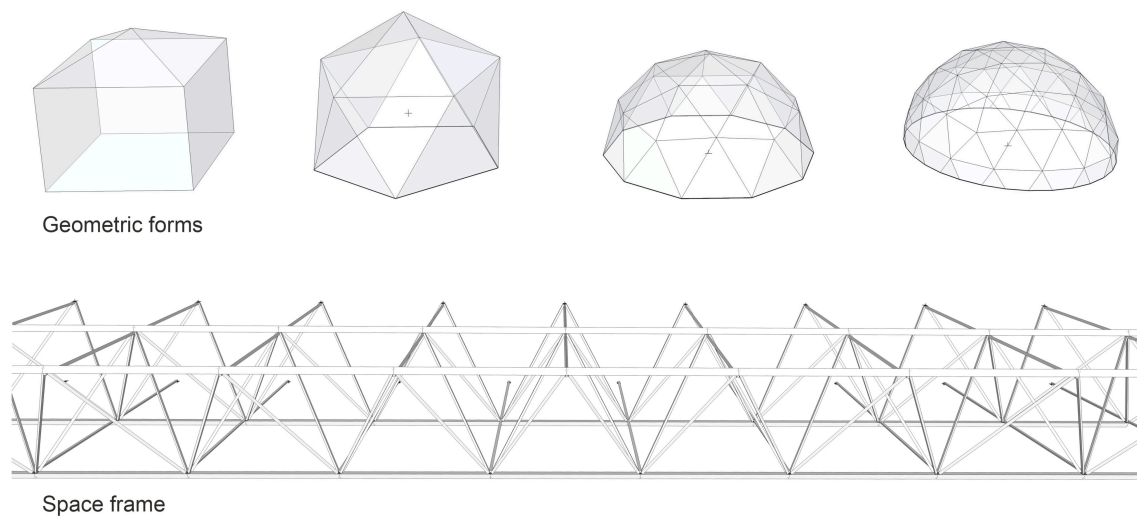

Figure 18

## Key benefits

The connector has various advantages over traditionally used connection systems. Some of the key benefits of the connector include:

- Easy and quick to construct using just a spanner or a socket set. No special tools or process is required to construct the structure.
- Accommodates the inconsistency of bamboo diameter and taper. Works with any type of bamboo.
- Flexible design allowing various configurations and possibilities

**Theme: Architecture, Engineering and Social Housing**

- The clamp is made of steel and can be re-used when required. And if not required it can be easily recycled.
- No holes required in bamboo retaining the integrity of the pole. Even if the bamboo cracks the clamping mechanism keeps the pole together retaining the strength of the pole.
- Easy to replace bamboo poles without affecting the entire structure if poles are damaged and need replacement.
- The smaller size of connection is easy to transport and promotes the use of locally sourced bamboo. This makes the system a sustainable alternative rather than transporting entire kits.

## Conclusion

The Bamboo Clamp Connector is designed for DIY market making it easier for everyone to build small to medium sized structures with bamboo. It overcomes some of the key issues related to connecting bamboo and will make bamboo construction available to more people. The modular aspect of the connector makes it a versatile joint that is suitable for many occasions.

At this stage a prototype of the connector has been built and more pieces are in production. The next stage of the design development would be to build various structures using the connections and carry out required structural engineering tests.

## List of figure captions

- Figure 1 – Green School near Ubud, Bali
- Figure 2 – Kolb’s cycle of experiential learning
- Figure 3 – Lashing connection using sisal rope
- Figure 4 – Square lashing using polypropylene rope
- Figure 5 – Bolted connection detail for the Bamboo Loveshack
- Figure 6 – Steel clamp connector used in Bamboo Greenhouse
- Figure 7 – Hub connector with polypipe
- Figure 8 – Steel hub connector with steel plates inside bamboo poles
- Figure 9 – Combination of hub connector and clamp used in Bamboo Greenhouse
- Figure 10 – Steel bracket connector
- Figure 11 – Plywood plates used as connector to create a truss
- Figure 12 – Prototype clamp connector fixed with a bamboo pole
- Figure 13 – Clamp component that grips on the bamboo
- Figure 14 – Central ring which connects to the clamp
- Figure 15 – Circular disk connects to the top and bottom of the central ring
- Figure 16 – Footing plate to fix the structure to the ground
- Figure 17 – Connection options with the connector
- Figure 18 – Design opportunities and geometric forms possible with the connector

## Illustration Credits

Figure 1-18 – Munir Vahanvati, Giant Grass

## References

- Hidalgo-Lopez, O. 2003. Bamboo The gift of gods. D’vinni Ltda, Columbia
- Villegas, M. 2003. New Bamboo Architecture and Design. Villegas Editores, Bogota, Colombia.

**Theme: Architecture, Engineering and Social Housing**

Gass, S; Drusedau, H; Hennieke, J. Dunkelberg, K. 1985. IL 31 Bambus –Bamboo. Karl KrammerVerlag, Stuttgart, Germany.

Farrelly, D. 1984. The Book of Bamboo. Sierra Club Books, San Francisco, United States of America.

Vege sack, Av; Kries, M; Vitra Design Museum; ZERI Foundation; CIERCA, 2000. Grow your own house Simon Velez and bamboo architecture. Vitra Design Museum, Weil amRhein, Germany

Frey, P.; Schaewen, D. 2013. Simon Velez Architect Mastering Bamboo. ActeSud, Arles, France

Minke, G. 2012. Building with Bamboo. Birkhauser, Basel, Switzerland

<http://www.domerama.com/when-geodesic-domes-and-noble-intentions-meet/>