

Role of Bamboo and Cane Development Institute in upgrading and disseminating bamboo handicrafts

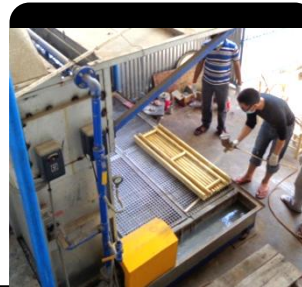

Abhinav Kant

Bamboo and Cane Development Institute

Lichubagan, P.O. Agartala Secretariat, Agartala, West Tripura, India – 799010

www.bcdi.in ; www.ncdpc.in

An Overview

- Set up in 1974 by O/o DC (Handicrafts), Ministry of Textiles, Govt. of India for developing proper techniques for treatment and preservation of cane and bamboo handicrafts items and also for providing necessary training.

- To professionalize the efforts & project BCDI as Centre of Excellence, running & management of BCDI provided to NCDPD by the Ministry of Textiles, Govt. of India in December, 2009.

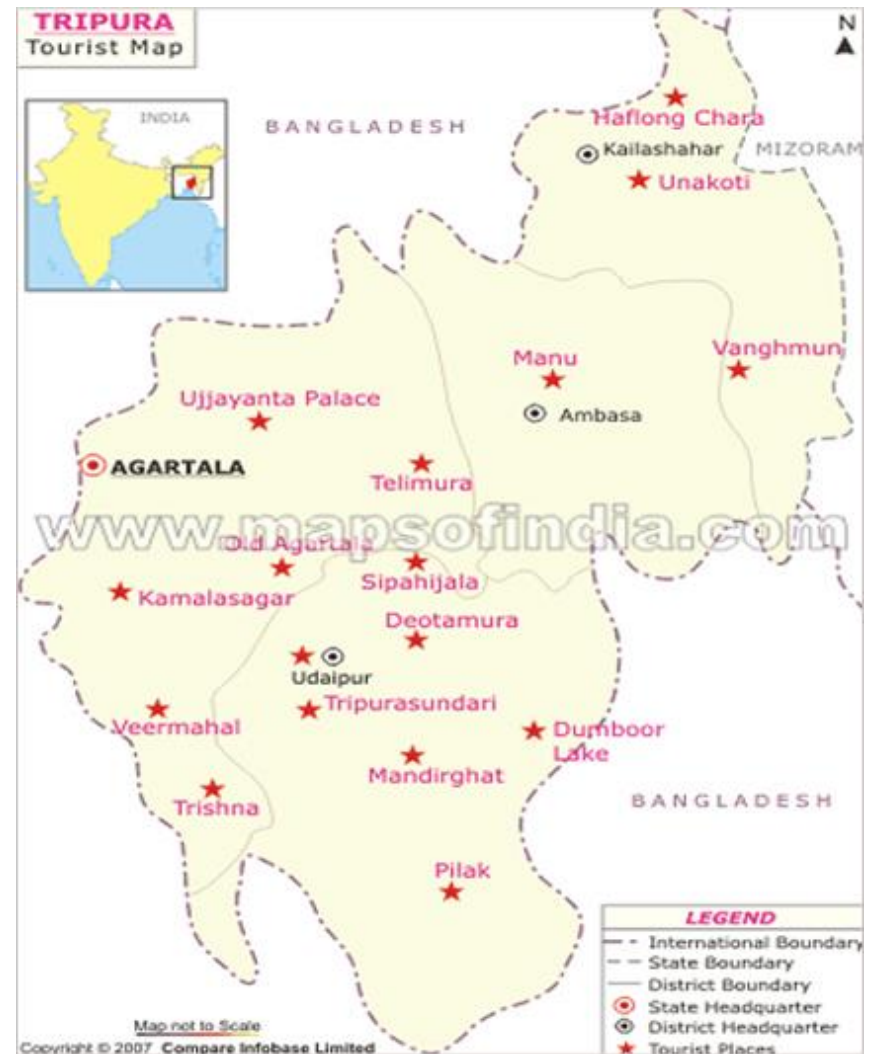

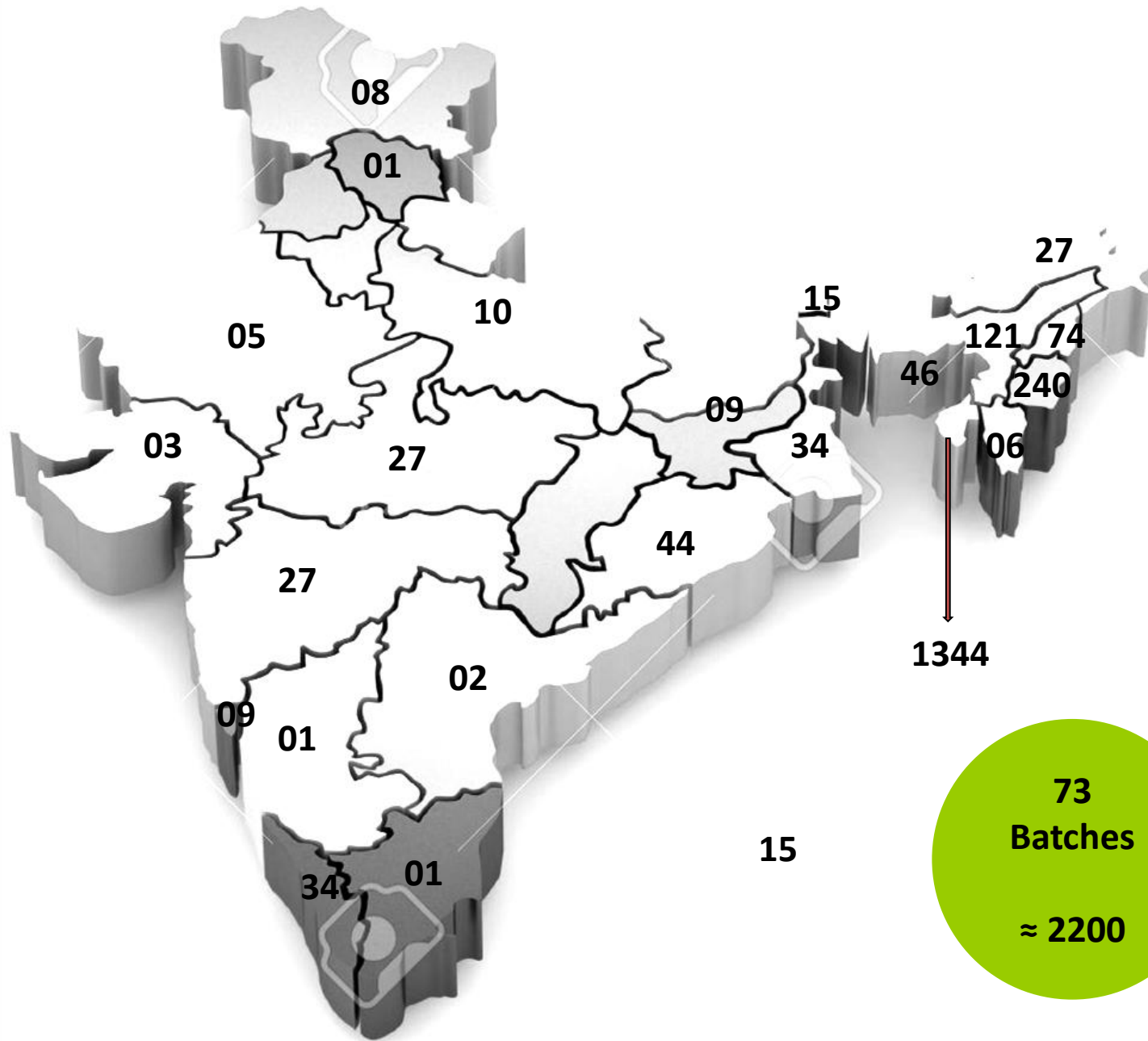

1344

73
Batches
≈ 2200





Skill/
Capacity
Develop
ment

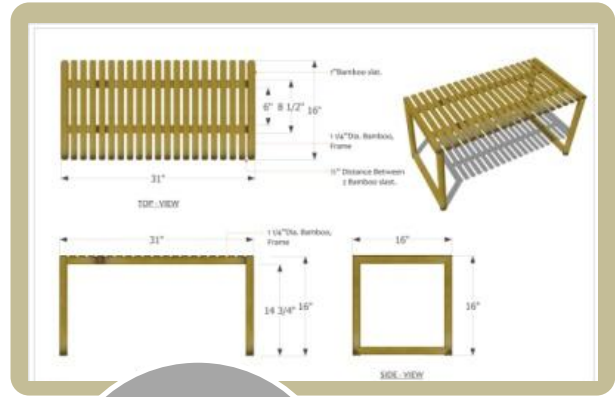

Design
services



Research
&
Develop
ment

BCDI



Product
Develop
ment



Market
linkage

INDIA IS SET TO BECOME THE YOUNGEST COUNTRY BY 2020

By 2020 India's 70% Population will be Youth. If these calculation keep going then by 2020 then every 2nd person in India will have a age below 29 which will make India worlds youngest country ever.

India has the world's
largest youth
population despite
having a smaller
population than China
:UN Report



Skilling India



FURNITURE



SKILL
DEVELOPMENT
PROGRAMME

BASKETRY

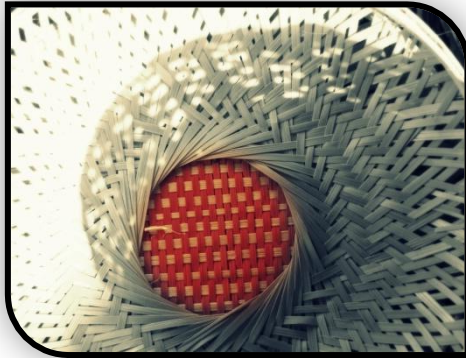

JEWELLERY



TURNING





Bamboo Furniture

- **Bamboo whole culm/ Slats**
- **Tools and other Paraphernalia:**

Hand Tools	Power Tools
Dao	Pillar Drill machine
Bench Vice	Hand drill machine
Hand Saw, Hack saw	Angle grinder
Hammer	Orbital Sander
Scraper, Chisel	Hand Planer
C – clamp	Hand Jig
Measuring Tape	Portable Cross cut
Hand Planer	

- **Finishing Material:** Sealer, Melamine, P.U.

FURNITURE PRODUCTS





FURNITURE PRODUCTS





FURNITURE PRODUCTS



Bamboo Basketry





Sliver making



Treatment



Coloring



Finishing



Use of Moulds



Sizing

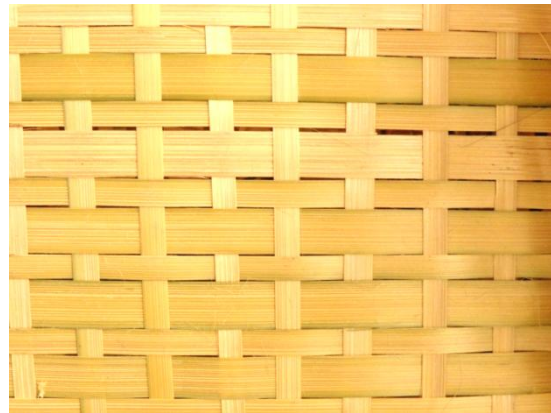
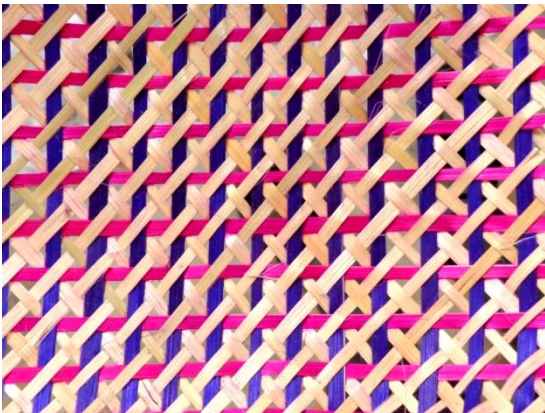
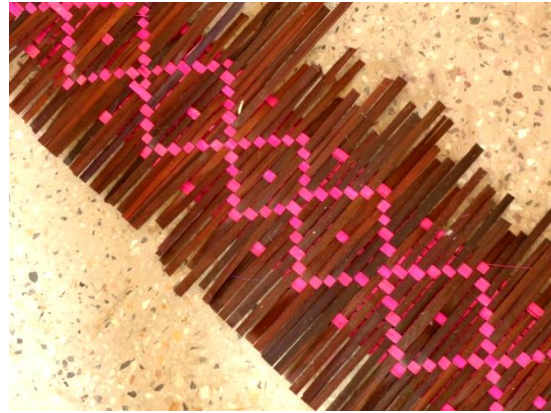
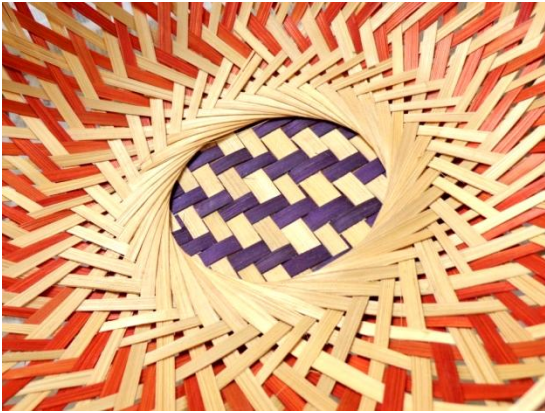
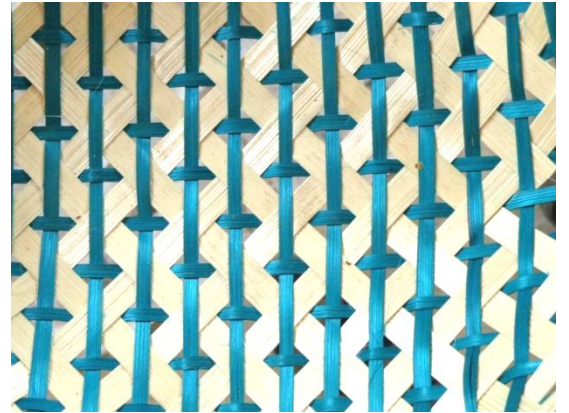
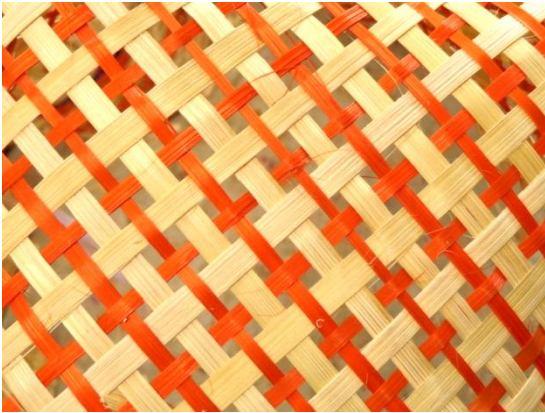

BASKETRY PRODUCTS

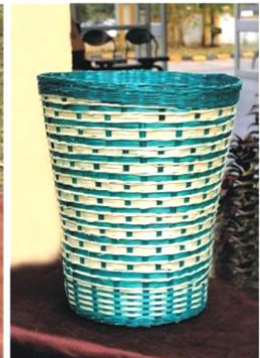

Bamboo Turning

A thick, dark gray L-shaped bar is positioned in the bottom-left corner of the page. It consists of a horizontal segment extending from the left edge towards the right, and a vertical segment extending downwards from the right end of the horizontal segment.

- Introduction to raw material and simple hand tools. Seasoning and preservation.
- Introduction to common operation pertaining to the Lathe.
- Introduction to Turning tools.
- Introduction to Spindle turning
- Practice on process in Spindle turning
- Learning the methods of finishing like buffing, polishing etc.

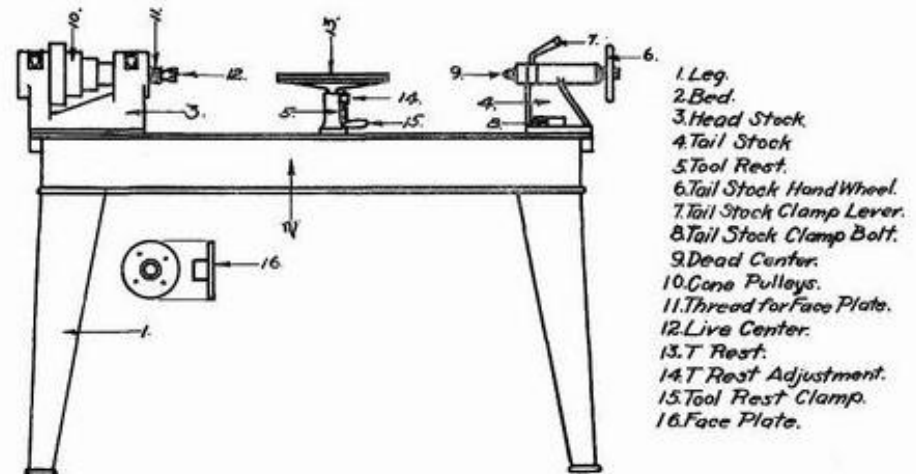



Roughing cut



Measuring



Marking



Finishing



Smoothing cut (large skew)



Convex cut

TURNING PRODUCTS



Bamboo Jewellery

JIG Jewellery



Scrapping & Drawing



Jig cutting & Sanding



Assembly & Finishing

Products



JINGLA Jewellery



Scrapping & Sanding



Pattern making & Cutting



Assembly & Finishing

Products



WEAVED Jewellery



Sliver Making



Weaving



Assembly & Finishing

Products



COILED Jewellery



Sliver Making



Coiling & Pasting



Assembly & Finishing

Products



JEWELLERY PRODUCTS



- **First Generation Artisans**
- **Setting up of Production Units**
- **Supply of necessary tools**
- **Generation of production order and marketing**



International Training Programmes



Bamboo Furniture Training for Bhutan Participants





Bamboo Handicrafts for Ethiopian Participants





Bamboo Basketry Training for Zimbabwe Participants



One Year PG Diploma on Bamboo Cultivation and resource utilization

Looking up the present scenario a trained manpower is required for the bamboo sector, where they have a holistic knowledge on bamboo and its application i.e. from production to consumption.

In collaboration with TRIPURA UNIVERSITY

- Bamboo diversity and resources
- Bamboo propagation and conservation
- Bamboo management and utilization
- Bamboo technology
- Bamboo design and product development



Design Services

- To provide new and innovative designs
- Improve the skills of the artisans
- Market acceptable products
- Organized at clusters
- Provided Market Linkages through participation in Different national / international shows



1 PERSPECTIVE



2 FRONT-VIEW









Foldable



Nested



Stackable



Knock-down



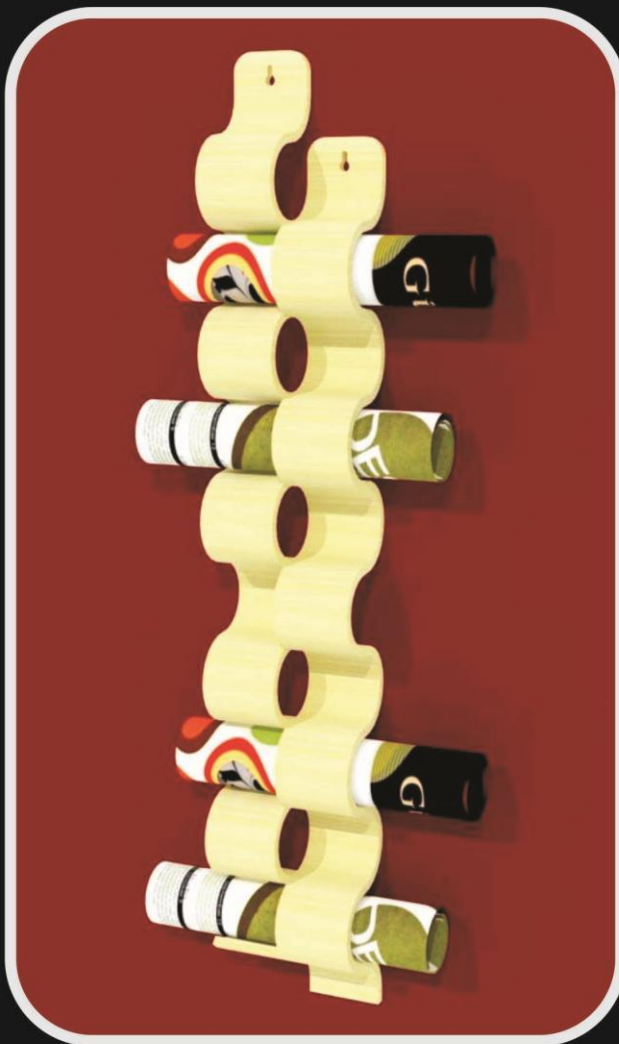

MATERIAL SWATCH



Bamboo Technology Centre & Product Development





R&D

Bamboo Glue Board



Bamboo Board- Furniture Items



BAMBOO CLOCK

Single layer bamboo board with hand painting



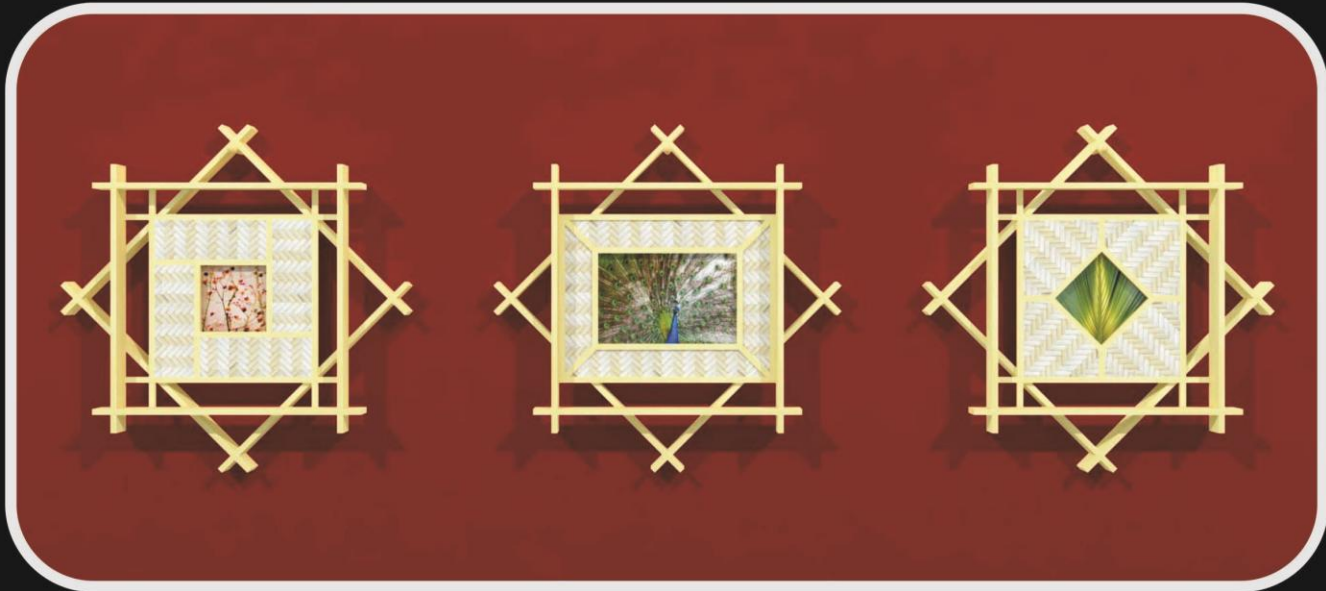

MATERIAL SWATCHES



MATERIAL SWATCHES



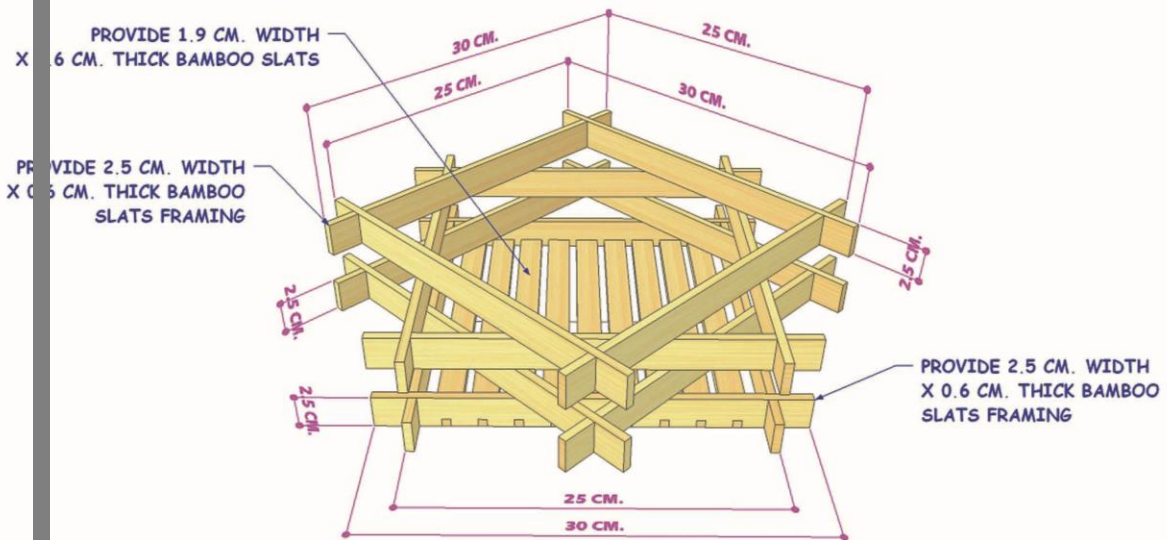

VIEWS

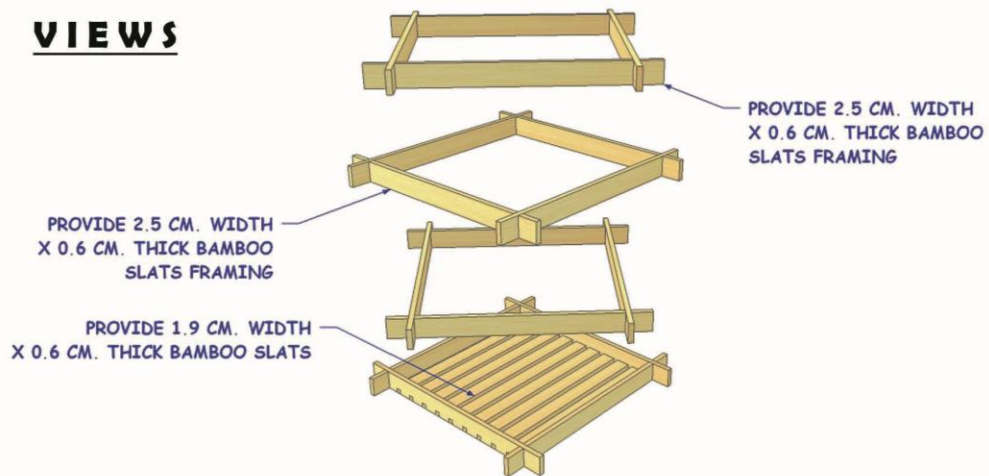

BAMBOO BOWL

PERSPECTIVE VIEW



MATERIAL SWATCHES

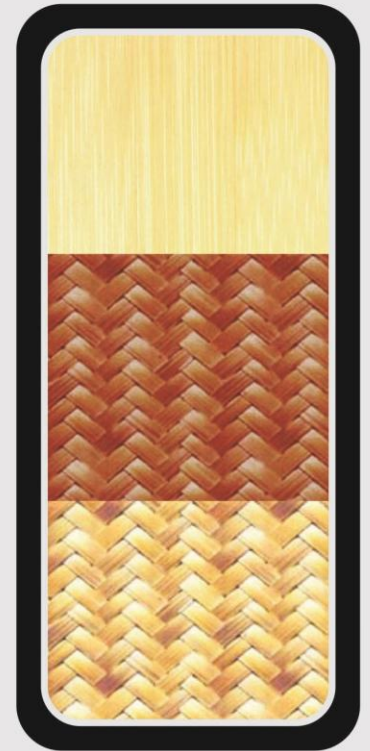
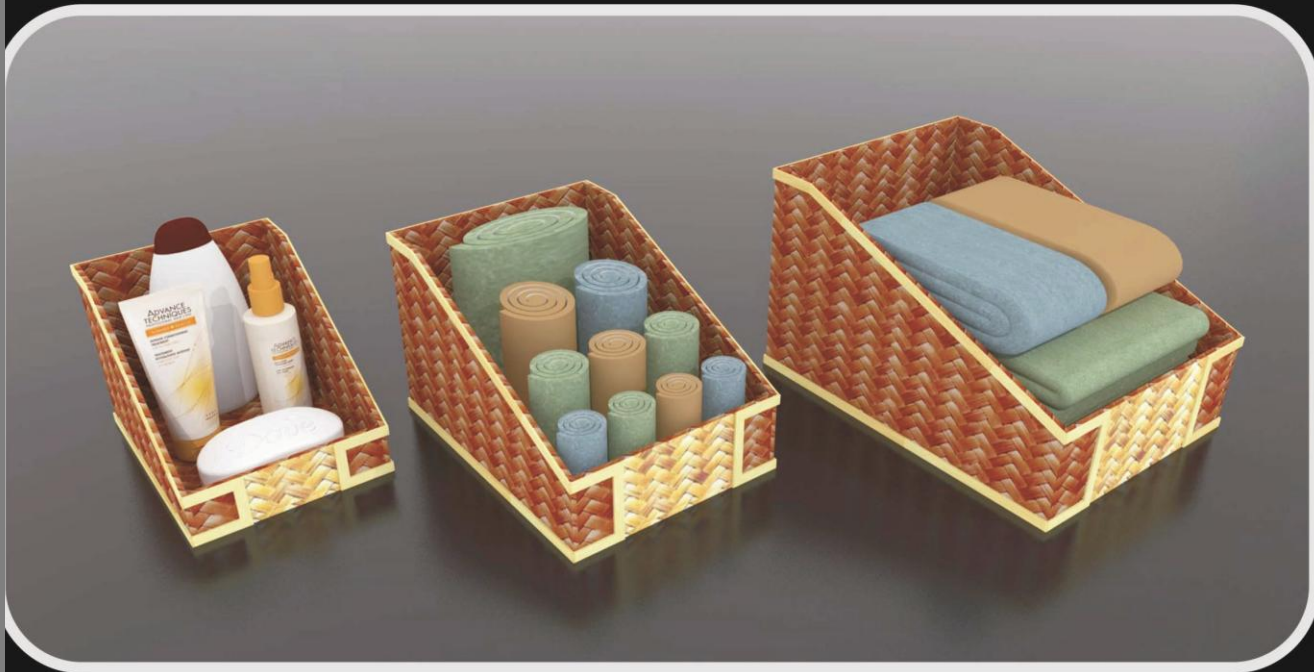

MATERIAL SWATCHES

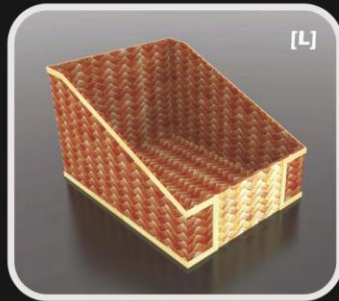
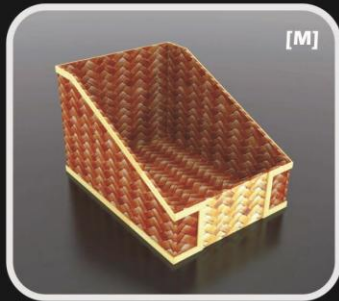
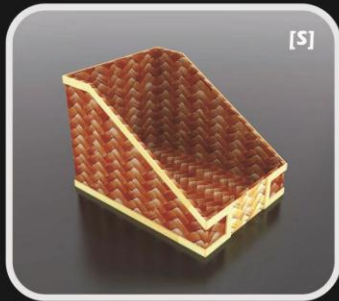
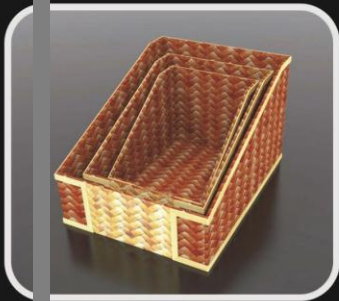

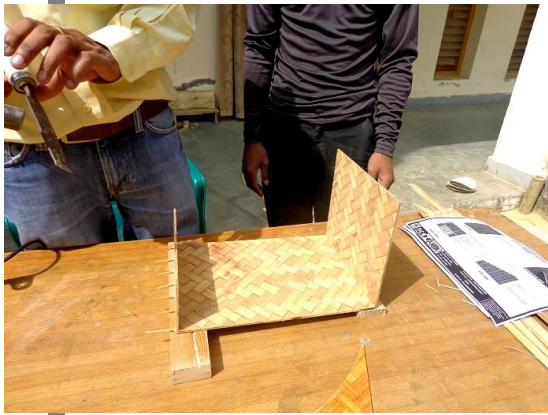

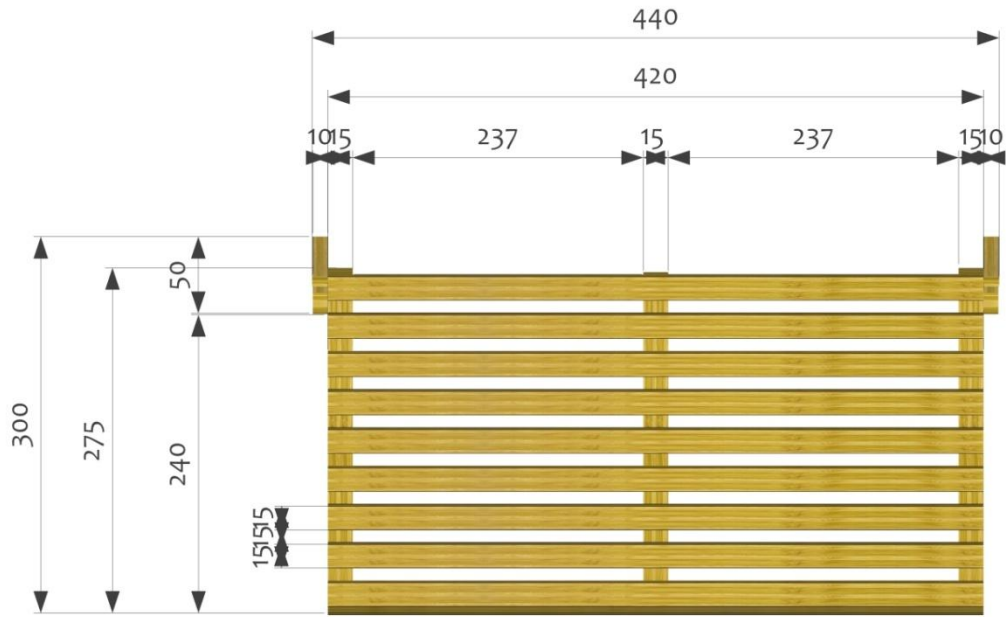

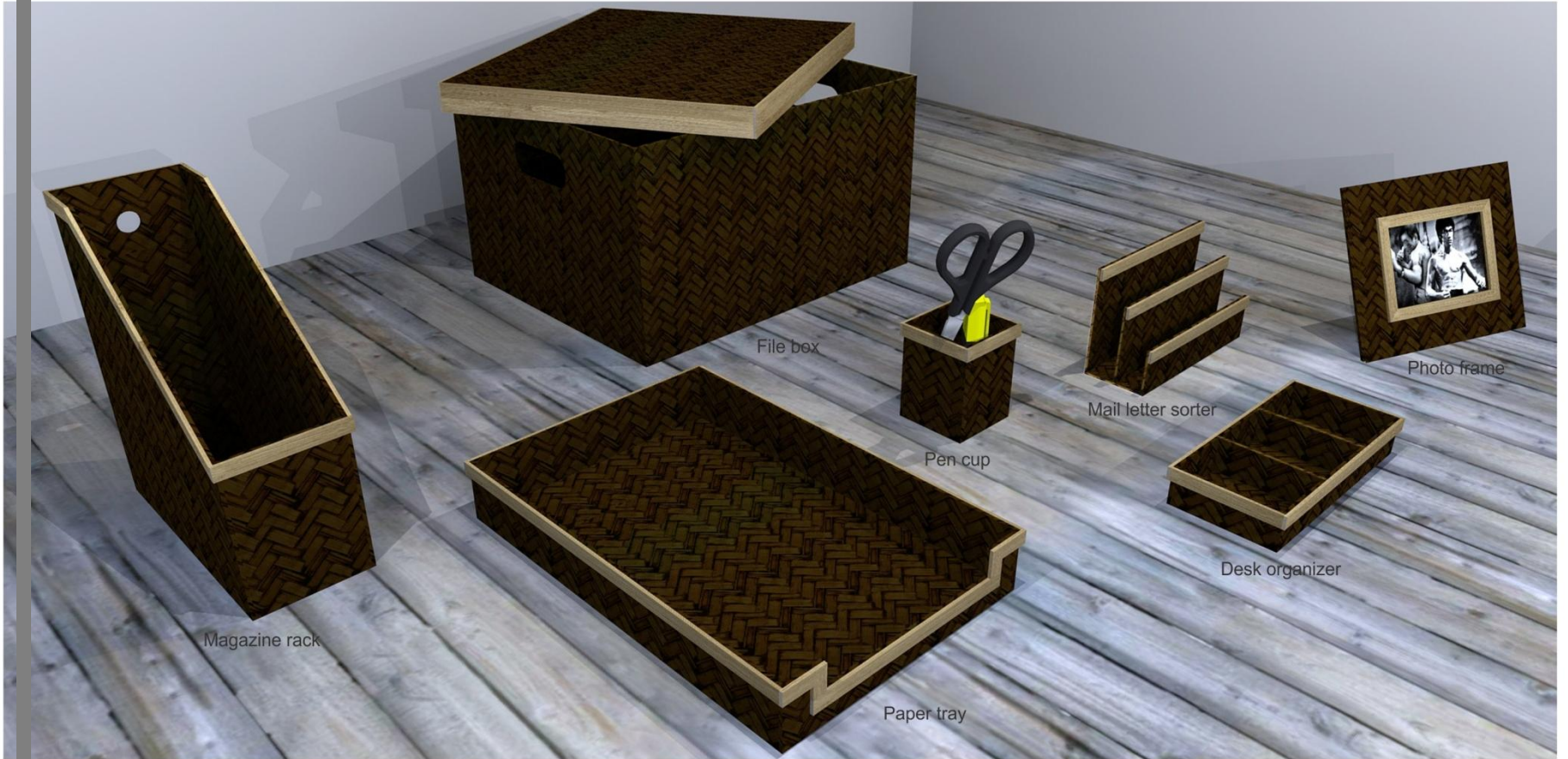

1

P E R S P E C T I V E

Shown

office desk accessories

combo pack



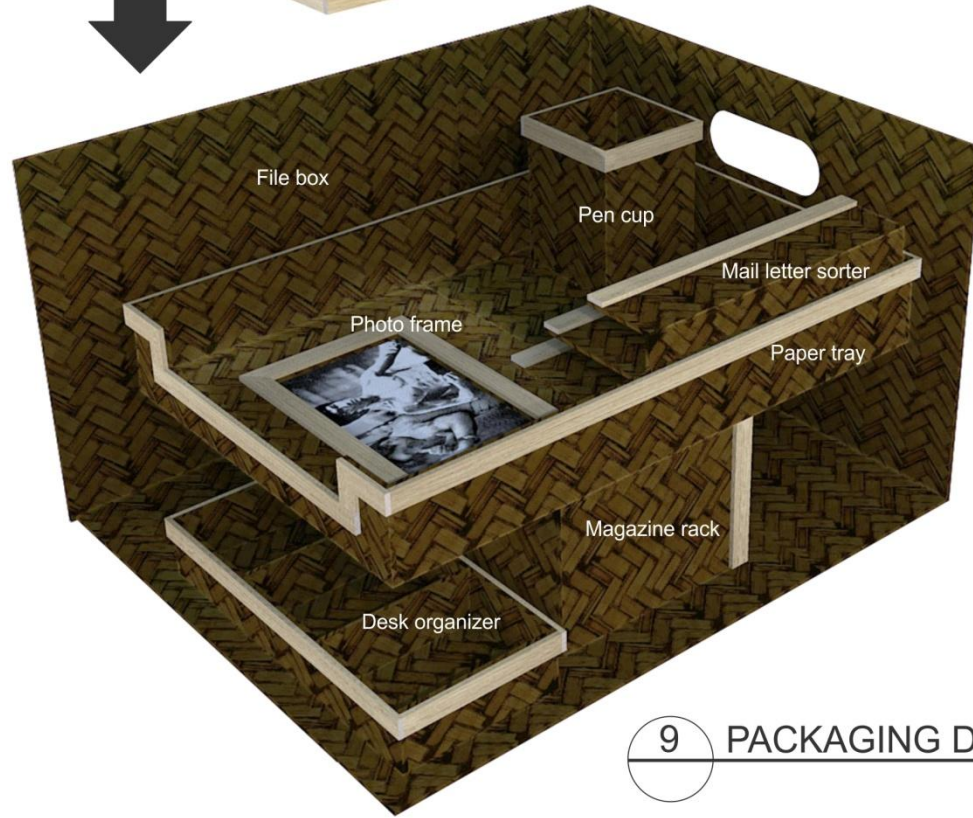

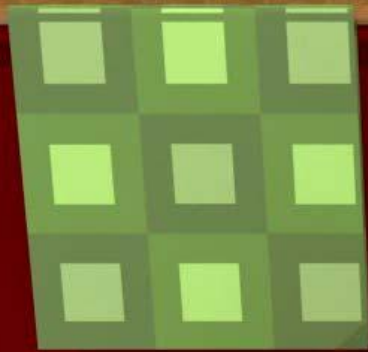

Loom Mat and Slat



Photo Chemical Machining



BCDI – Market Linkages

Participation in National / International shows conducted by EPCH and other agencies.

- TEXTRENDS
- Indian Handicrafts and Gift Fair
- Home Expo
- IFJAS





FARE | EXHIBITIONS

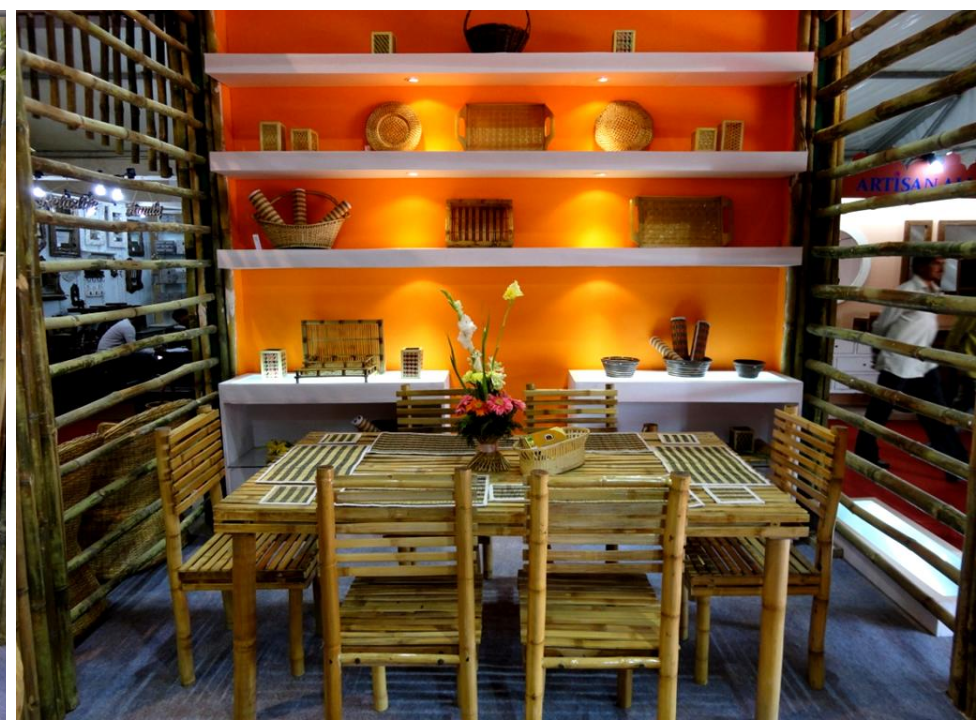



INDIAN CONTEMPORARY

Eco-friendly classic - modern look handcrafted
bamboo jewellery from North East, developed by
Bamboo and Cane Development Institute
during

IIFJASI 2

Indian Fashion Jewellery and Accessories Show 2012
13-15 July 2012, India Expo Centre & Mart, New Delhi, NCR



“BCDI is providing strategic services including Education, Sales Promotion, Designing, Product Development and Trainings for Handicrafts made out of Bamboo, Cane and Allied natural fibre material”

Thank You!